



VERPAN

In- and outdoor

Verner Panton

Danish designer (1926 -1998)

Among the giants of Danish design, Verner Panton established a unique reputation for his exuberant originality and tireless experimentation. Panton created lamps, furniture and textiles – and was also a sought-after interior designer. Although he was at the forefront of mid-century Danish Modern, Panton's contribution was anything but mainstream. He enthusiastically embraced new materials, he splashed with a bold colour palette, and he playfully imbued many of his sculptural creations with a strong graphical expression – without ever compromising on quality or workmanship.

Panton's iconic designs have emerged as contemporary design classics – as strikingly inventive now as they were 50 years ago.

Panton's interior installations have attained legendary status. The most famous examples are the 'Visiona' ship installations for the Cologne Furniture Fair (1968 and 1970), the Spiegel publishing headquarters in Hamburg (1969) and the Varna restaurant in Aarhus (1971).

Verner Panton in his own words:

"The main purpose of my work is to provoke people into using their imagination. Most people spend their lives living in dreary, grey-beige conformity, mortally afraid of using colours. By experimenting with lighting, colours, textiles and furniture and utilizing the latest technologies, I try to show new ways, to encourage people to use their imagination and make their surroundings more exciting".

Marianne Panton (Verner Panton's wife):

"For 35 years, I had the pleasure of taking part in the world famous design work by my husband Verner Panton. Accordingly, it is a wonderful experience for me now to see how popular the Verpan products have become - and just how timeless his designs have turned out to be.

Of course I'm very proud that there is still so much interest in my husband's design and his lifework. It would have made Verner happy, and it certainly makes me happy. Verner had very clear attitudes regarding his work and regarding shape, colour and function. At the same time he made conscious and brave use of different materials. Also in a way and a combination which often led to his contemporaries disparaging the "timelessness" of his design. The great interest in his design today proves the opposite".

Verpan

Founded in 2003

Verpan is - much like Verner Panton - a product of the Danish design tradition, which have put Denmark on the world map for functional, modern and unique design.

In close collaboration with the Panton estate - especially widow Marianne Panton - Verpan has acquired the production and sales rights to a significant part of Verner Panton's designs. In 2003 the production of lighting was initiated and in 2010 a furniture range was added. A continuous process of picking and choosing products from the vast treasure chest of Panton's work, will bring many more items to life again.

All of the Verpan products stand out as some of the most elegant and memorable of Verner Panton's designs. Products that create life, sound, movement, colour and light - design that brings value into the visual world around us.



Marianne and Verner Panton in the Cloverleaf sofa during Visiona 2 (1970)



Suitable for all exteriors as well as hospitals, education and office facilities, restaurants, receptions etc.



100% RECYCLABLE MATERIAL

FDA APPROVED FOR USE WITH FOOD

UV - RESISTANT

WITHSTANDS
HIGH-PRESSURE CLEANING

Cloverleaf Sofa

in- and outdoor

Designed by Verner Panton in 1967

This new version of the Cloverleaf in hardwearing polyethylene (PE) can be used both outdoors and in.

Verpan designed this version because the qualities and infinite seating options featured in the upholstered version of Cloverleaf are also desirable on patios, and in reception areas, waiting rooms etc.

With the guidance and assistance of technicians and engineers, we have manufactured a model in polyethylene. Not only can its UV-resistant surface withstand sun, wind and the changing seasons, it also meets the professional cleaning requirements of the various sectors of the healthcare system. Its tough surface also makes Cloverleaf an ideal choice for the hospitality industry or a busy front office.





GAARD MUSEUM



CAN BE WATER OR SAND FILLED
FOR PERMANENT REQUIREMENT



Verner Panton
UERPAD



WITHSTAND SUN, WIND
AND THE CHANGING SEASONS

WATER RESISTANT

2° SLOPE ON SEAT

A close-up photograph of a white, curved, modular component, likely part of a larger system. The component has a smooth, glossy finish and a dark circular opening. The lighting creates soft shadows and highlights the curvature of the material.

HIGH DURABILITY

MODULAR SYSTEM



CAN BE FIXED TO
THE GROUND

EASY ASSEMBLY



39 Yellow



77 Orange

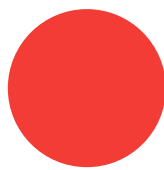

47 Red



44 Lime green

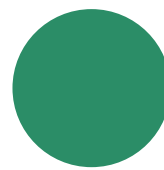

45 Grass green

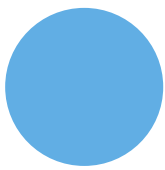

76 Sky blue

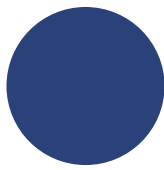

46 Dark blue

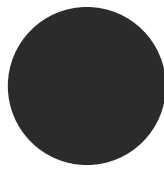

43 Black

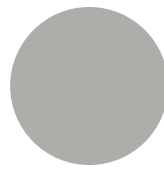

78 Grey



27 Opal white

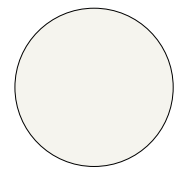

75 White

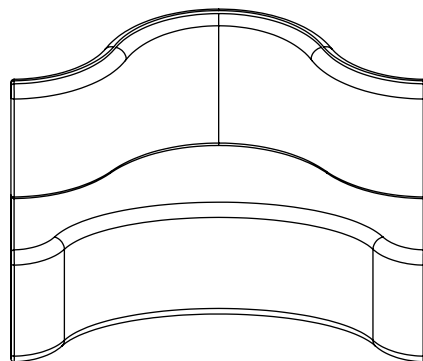
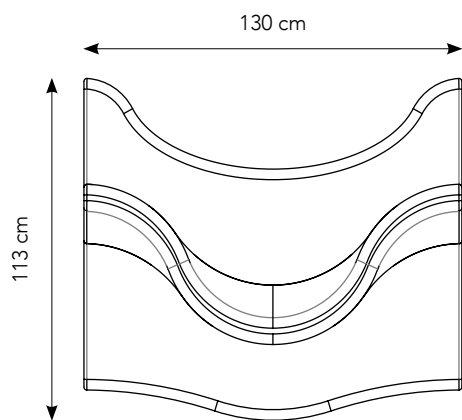
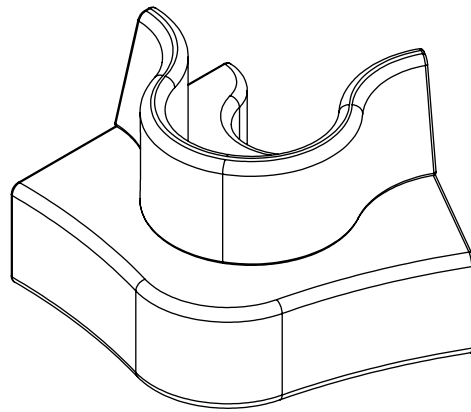
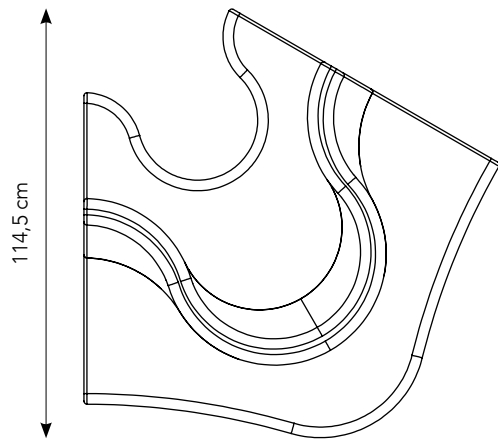
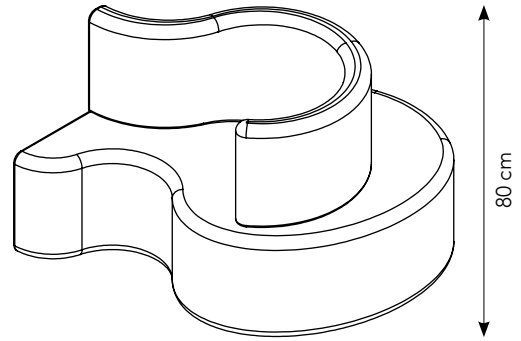
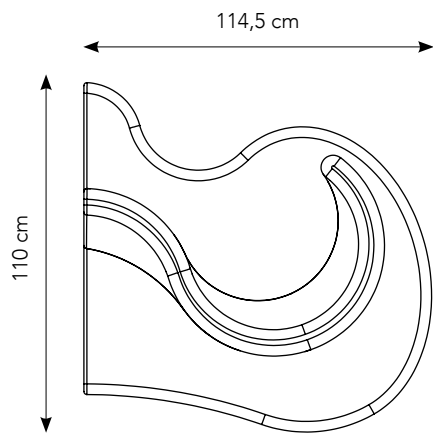



Illumesa light table

Interpreting "Table Lamp" quite literally, the Illumesa ingeniously adds light to a table. A single light bulb provides a diffused, soft glow through the opaque white acrylic parts. This combination of pleasantly practical light and geometric simplicity is another playful example of Verner Panton's investigations into form, materials and function. The fun character of the lamp makes Illumesa an interesting accessory that also happens to provide functional table space.

Suitable for use indoors as well as outdoor.



Panto Pop chair

Designed by Verner Panton and launched in 1969, the Panto Pop stackable chair is an iconic design piece.

Recently Verpan under license updated the Panto Pop by adding UV stabilizers to the thermoplastic mix producing a more practical version for outdoor use. The addition of the drainage hole at the base of the seat now allows water to escape more freely improving both maintenance and durability.

One of Verpan's most recognizable pieces, the Panto Pop is stackable and available in white and red, adding a pop of colour and fun to any environment.

Suitable for use indoors as well as outdoor.



ILLUMESA
table

Height: 37 cm
Diameter: 78 cm

Light table made of white acrylic,
for indoor and outdoor use

Available in white



PANTO POP
stacking lounge chair

Height chair: 54 cm
Seat height: 81 cm

Stackable. PP material UV stabilizer added.
For indoor or outdoor use.

VERPAN APS
EGESKOVVEJ 29
8700 HORSENS
DENMARK

+45 76 58 18 82
INFO@VERPAN.COM
WWW.VERPAN.COM

